

Left Hand shown Mirror image for Right  
 Make from 6061 T651 aluminum plate

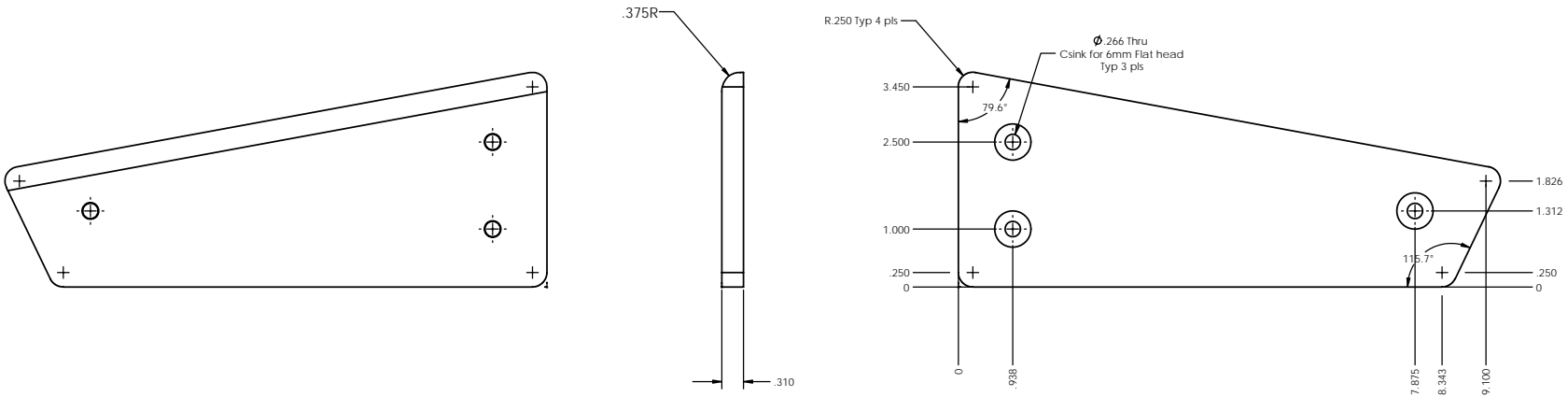

Trim Tabs late 98-99  
 GP1200

DIMENSIONS ARE IN INCHES UNLESS OTHERWISE SPECIFIED		DRAWN: _____ CHECKED: _____ TITLE: _____
DESIGNER: _____ PROJECT NUMBER: _____ THIRD PLACE DECIMALS: _____ FIFTH PLACE DECIMALS: _____	REVISIONS: _____ DATE: _____ COMMENTS: _____	SIZE: D DWG. NO: TC1 SCALE: 1:1 WEIGHT: _____ SHEET 1 OF 1

PROPRIETARY AND CONFIDENTIAL  
 SEE NOTIFICATION CONTAINED IN THIS  
 DRAWING IS THE SOLE PROPERTY OF  
 BOEING COMPANY NAME HERE. ANY  
 REPRODUCTION OR TRANSMISSION OF  
 THIS DRAWING WITHOUT THE WRITTEN  
 PERMISSION OF BOEING COMPANY NAME HERE, IS  
 PROHIBITED.